

SECTION A-A

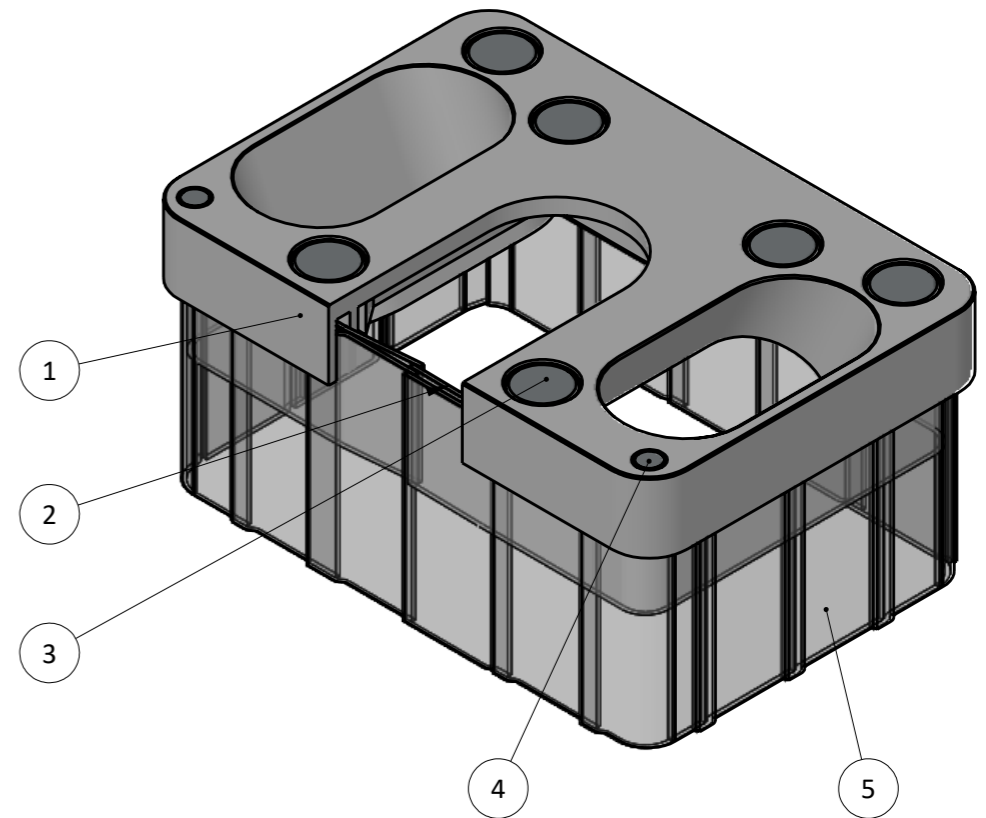

5	220224 - HARJAS	DEFAULT	-	PVC 0.007 PLASTICIZED		0.01	17
4	02608 - NEODYMMIMAGNEETTI 8X3	DEFAULT		NEODYMIUM N33 ZN	Ø8X3	0.00	2
3	02606 - NEODYMMIMAGNEETTI	DEFAULT		NEODYMIUM N33 ZN	Ø19,5X3,8	0.01	6
2	220132 - HARJAKEHÄ	DEFAULT		PVC 0.007 PLASTICIZED		0.04	1
1	220131 - IMUSUULAKE	DEFAULT		PETG FILAMENT		0.27	1
POS	DRW.NUMBER - DESCRIPTION	CONFIGURATION	REV	MATERIAL	DIMENSIONS	KG/PCS	QTY
DrwNote				ID Number   Title			
				<b>220130 - IMUSUULAKKEEN KOKOONPANO</b>			
Construction Type ASSEMBLY		Standard	Dimensions 130x190x91		Supplementary title		
Material			Mass 0.47 KG		Product CADVIS CNC ROUTER	Configuration DEFAULT	
General Tolerance			Revision		Approved By J.Mäkinen	Checked By	Designed By J.Mäkinen
			Rev. Released Date		Approved Date 9.11.2022	Checked Date	Designed Date 23.07.2022
			Revision Description				
Surface Finish Ra	Manuf. type Tolerance	Manuf. type Tolerance	Manuf. type Tolerance		FileName 220130 - IMUSUULAKKEEN KOKOONPANO		
					Responsible Department PRODUCT DEVELOPMENT		
SurfaceTreatment					Owner / Legal Rights CADVISION.FI - CC BY-SA		Date of Issue
Coating PAINT					Document Type DRAWING (DEFAULT)		Sheet 1 / 1
Color RAL 9010 Pure white					Document Status PRODUCTION		Size A3 Scale 1:2